



HAL
open science

Efficiency of periphery trench for reducing the impact of surface subsidence on structures using 1g physical modelling

Marwan Al Heib, Jean-Bernard Kazmierczak

► To cite this version:

Marwan Al Heib, Jean-Bernard Kazmierczak. Efficiency of periphery trench for reducing the impact of surface subsidence on structures using 1g physical modelling. 3. European Conference on Physical Modelling in Geotechnics (EUROFUGE 2016), Jun 2016, NANTES, France. pp.191-196. ineris-01854224

HAL Id: ineris-01854224

<https://ineris.hal.science/ineris-01854224>

Submitted on 4 Sep 2018

HAL is a multi-disciplinary open access archive for the deposit and dissemination of scientific research documents, whether they are published or not. The documents may come from teaching and research institutions in France or abroad, or from public or private research centers.

L'archive ouverte pluridisciplinaire **HAL**, est destinée au dépôt et à la diffusion de documents scientifiques de niveau recherche, publiés ou non, émanant des établissements d'enseignement et de recherche français ou étrangers, des laboratoires publics ou privés.

Efficiency of periphery trench for reducing the impact of surface subsidence on structures using 1g physical modelling

M. Al Heib & J-B Kazmierczak

INERIS- Parc Technologique Alata - BP 2, 60550 Verneuil en Halatte, France

ABSTRACT: Underground mines induce a surface subsidence. The existing structures and infrastructures can be damaged by the strain and settlement of the soil in the subsided zone. Mitigation methods exist for reducing the impact of the subsidence on the existing structures. One of them is the periphery trench, the method consists in cutting the soil around the existing building then filling the trench with a compressible material. The effect of horizontal strain will be absorbed by the partial closure of the trench. Physical modelling (1g) tests were carried out to evaluate the optimal dimensions and to determine the characteristics of the filling materials that can be recommended. Thanks to results the effectiveness of the trench was confirmed; operational recommendations were made.

1 SUBSIDENCE DESCRIPTION AND CONSEQUENCES

1.1 Subsidence mechanism and components

Subsidence is the consequence of mine excavations, tunnels and the collapse of natural cavity. Subsidence causes ground surface deformation, the subsidence characterized by sagging of the ground surface producing more damage, over larger areas, affecting nearly all structures and infrastructures. The subsidence breaks up classically into a vertical movement of the ground, called subsidence, and a horizontal displacement (Peck, 1964, Al Heib, 2008). Figure 1 presents the theoretical curves of vertical displacement, tilt, horizontal strain for an underground mine. The vertical displacements are obtained by direct survey measurements. The others parameters are estimated using empirical and analytical approaches (Lack et al., 1992, Deck et al., 2003). The maximum damages observed on structures are located in the zone of maximum horizontal extension strain defined by the broken angle θ (Figure 1).

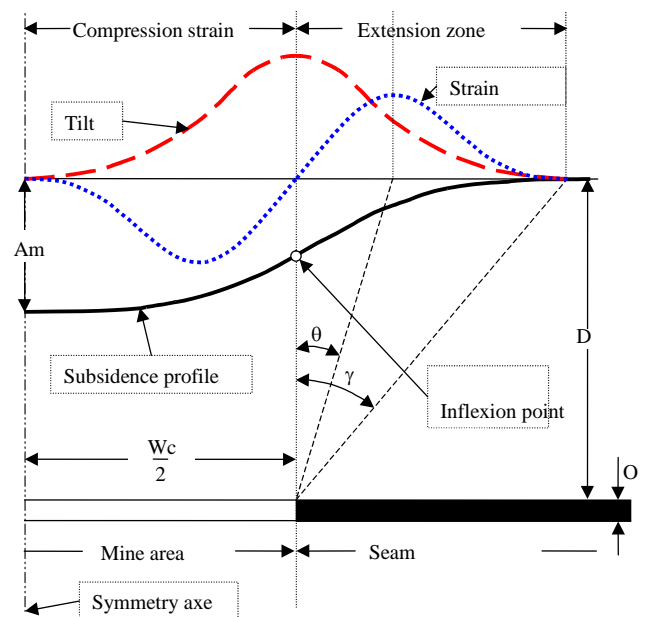

Figure 1. Subsidence parameters (O: layer open, Am: maximal subsidence, γ and θ : influence angle and maximum strain angle, D: depth, Wc: critical width).

1.2 Damages of structures

The Figure 2 idealizes the different movements that can affect the structure due to surface subsidence. The vertical component of subsidence causes changes in ground gradient, which can adversely affect, for example, drainage, tall buildings and machinery in factories. The tilt, horizontal strains (extension and compression) and curvature are the causes of the most commonly observed type of subsidence damage. Extension is characterized by the

pulled open joints in masonry. The compression strain results in the: squeezing-in of voids such as doors and windows and the horizontal movements of masonry blocks.

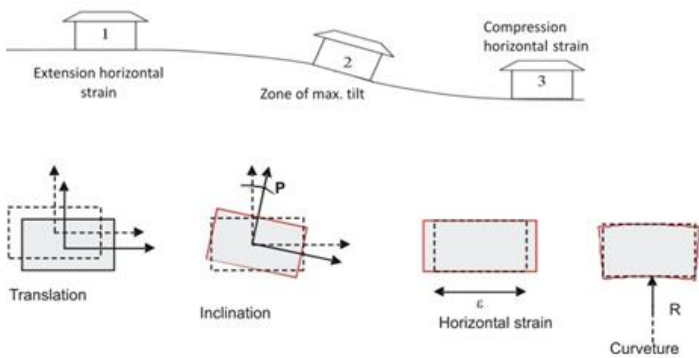

Figure 2. Different types of movement affecting a structure (Deck et al., 2003).

The Figure 3 shows the effect of compression strain due to the subsidence on an existing structure and the ground around the structure.



Figure 3. Example of serious structure damages due to subsidence – Iron mine – Lorraine – France.

1.3 Mitigation methods of subsidence consequences

Various mitigation methods have been developed and applied to reduce subsidence influences on numerous surface structures. (Bazanzurita et al., 2012). The main methods are classified on three categories: i) The reduction of the hazard intensity; ii) The strengthen of the structure by increasing the capacity of the structure to resist against the hazard; iii) The reinforcement of the soil and the foundation.

The trench presents a potential mitigation solution due to the low cost and the application of the method for individual houses. The periphery trench is a vertical slot realized in the existing soil at a horizontal distance from the structure. For security reasons, the periphery trench should be filled with a compressible natural or artificial material (Figure 4).

The paper treats the effectiveness of the periphery trench.

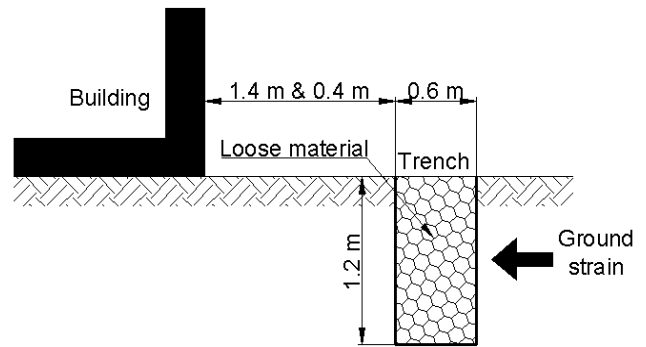

Figure 4. Presentation of peripheral trench technique.

Peng et al. (1996) followed the behavior of 12 individual houses to determine the performance of the trench. The houses were under the influence of subsidence induced by a longwall of deep coalmine, the horizontal strain varies between 5 mm/m and 15 mm/m (Figure 5). The trench reduced the tension strain about 35% and 65% for the compression strain.

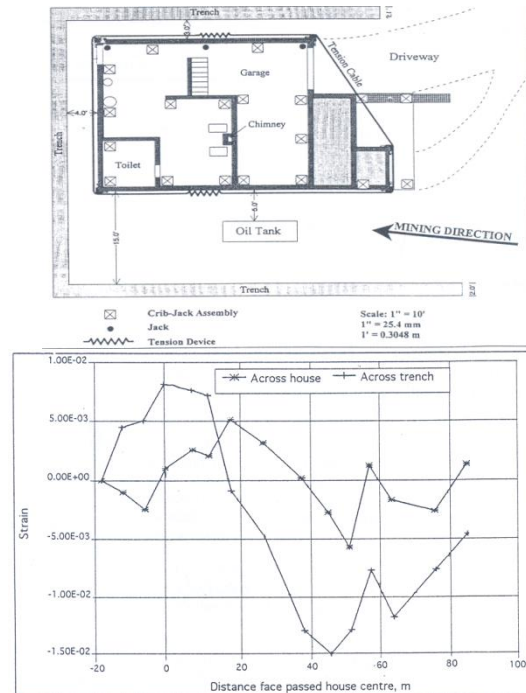

Figure 5. The effect on the trench on the strain from in-situ measurement in USA (Peng et al. 1996).

2 PHYSICAL MODELLING

2.1 Introduction

Few back analyses exist to demonstrate the efficiency of the method and to give the engineers operational recommendations. However, the following points can be summarized from the bibliography:

- The gravel, coke, peat can be used as filling materials, but few data exist of the mechanical properties.

- The width of the trench varies between 40 and 60 cm, the distance between the structure and the trench limit is about two meters and the depth of the trench varies between 60 cm and one meter.
- The trench is placed under the level of the foundation.

2.2 Physical modeling description

INERIS developed a large physical model to study the soil-structure interaction due to the different ground movements. Figure 6 shows the small-scale physical model of soil-structure system (2*3*1 m). The vertical displacement applied using electric jack. In this physical model, the analogue soil is Fontainebleau sand; This sand is very smooth and for our purposes the category NE 34 sand was chosen. The considered grade of Fontainebleau sand ($D_{50} = 200 \mu\text{m}$) has on the one side less negative effects, due to scale ratio of the physical model, on the transfer of movement from soil to structure than another type of sand but on the other side, allows the use of DIC with a satisfying accuracy of the displacements determination (Al Heib *et al.* 2013). The friction angle of the sand varies from 29° to 42° depending on the state of compaction.

Herein, the following remarks related to similarity conditions are addressed: (i) Firstly, this model of the soil does not allow representing the real soil behaviour because of its cohesionless character. (ii) Secondly, the similarity requires the scale factor of the stress σ_s and the Young's modulus E_s must be reduced by $1/n$: $\sigma_s^* = E_s^* = 1/n$ ($n=40$); because the stress and the Young's modulus of a point are increasing with the depth H . However, the values of the stress and the Young's modulus are quite identical when using the small-scale model because of its shallow depth. This means that two parameters σ_s and E_s do not meet the similarity conditions. (iii) Thirdly, the grain size effect has not been studied deeply. For the modelling in centrifuge (ng), it was found that the ratio between a shallow foundation length L and the mean diameter of grains D_{50} should be greater than or equal to 35 so that the grain size effect is negligible ($L/D_{50} \geq 35$), see Garcia (2001). However, there is no rule for the case of modelling under normal gravity ($1g$). The ratio L/D_{50} is equal to 1250 ($L=250 \text{ mm}$, $D_{50}=200 \mu\text{m}$) and can be reasonably sufficient to neglect the grain size effect.

Measurement of surface displacements is achieved by means of stereo digital imagery. Digital Image Correlation (DIC) technique was adopted to determine the displacements and the deformations. This allows monitoring the whole top surface of the ground and more especially where ground movements happen. The relative position of the 2 cameras is very precisely known and allows the determination of 3D displacements and deformations of the

soil and structure surfaces (Figure 6). The two high-resolution digital cameras have a maximum frequency of 8 images/second at full resolution. They have to be calibrated before the start of a test by the use of a test pattern. A good calibration allows obtaining very precise measurements with an error of 1/100 of a pixel in good conditions: this corresponds to $10 \mu\text{m}$ when 1 pixel is equal to 1 mm.

2.3 Trench physical modelling

Physical model was used to study the impact of the trench in subsidence reduction. The building modeled by two parts. The first one is a hollow slab while the second one is composed of lead powder in a plastic bag. This allows the model to present a stiffness and a stress transmitted to the ground equivalent to the prototype's ones. This small scale model is laying on the ground without any foundation parts. The Table 1 presents the characteristics of the building model (small-scale model and prototype).

Melamine foam was chosen for its ability to deform in compression, its physical aspect, and its ease of implementation. A great difference exists between the elasticity modulus of the melamine (1-2 kPa) trench model and that of the Fontainebleau soil model (5-10 MPa). The melamine foam is about 500 to 2000 times softer than the Fontainebleau sand.



Figure 7: Trench position and foam material used to fill the trench in physical model.

Table 1. Characteristics of building model.

Characteristics	Model	Scale factor (n)	Prototype
Width (m)	0.25	40	10
Length (m)	0.25	40	10
Total height (m)	5.5E-3	40	0.22
Young's modulus (MPa)	2200	40	88000
Axial stiffness (MN)	0.66	40^3	42240
Bending stiffness (MN.m)	2.03E-7	40^5	20.79

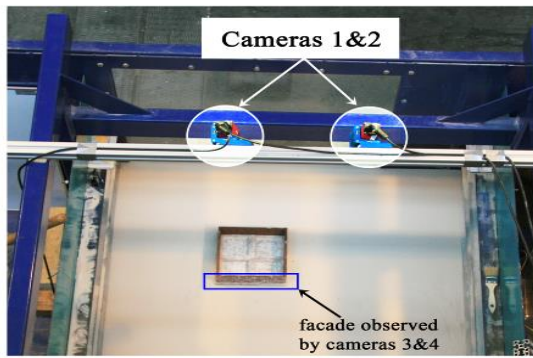

(a)



(b)

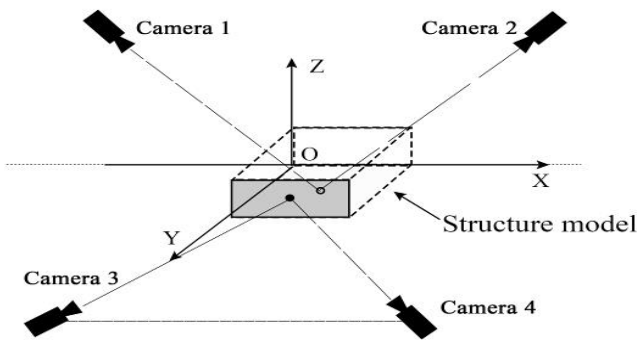

(c)

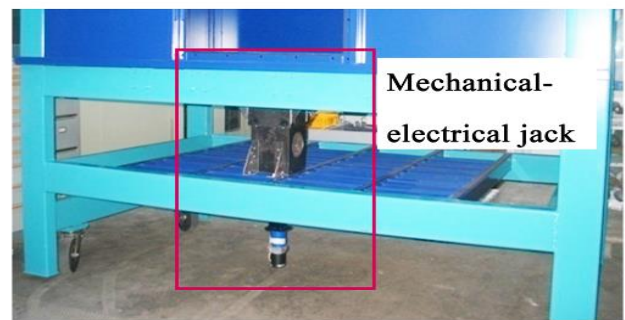

(d)

Figure 6. 3D physical model of soil-structure system. (a) Two cameras monitoring the soil surface movement, (b) Two cameras monitoring one facade of the structure, (c) Position of cameras, and (d) Mechanical-electrical jack.

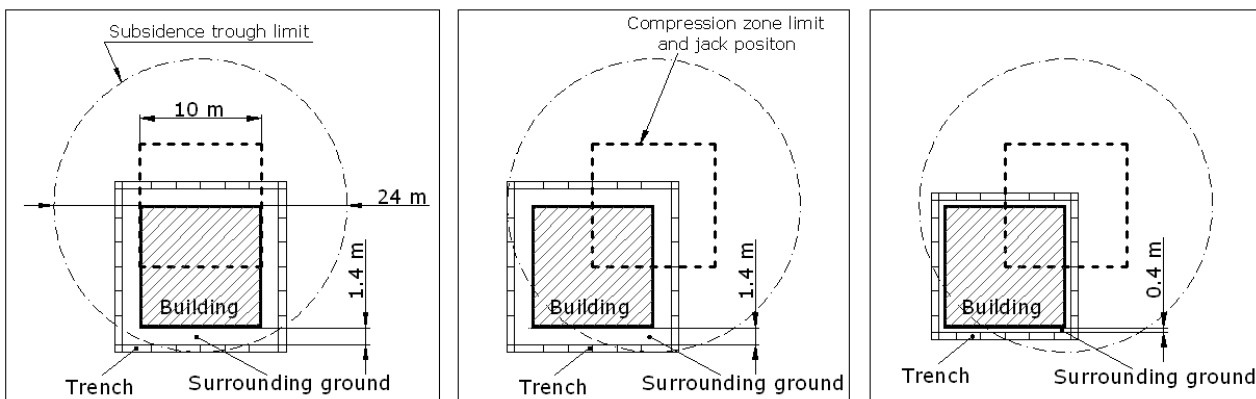

Figure 8. Different configurations of the tests: (left) Trench placed at 1.4 m from the building located in maximum slope zone; (centre) Trench placed at 1.4 m from the building located in tensile zone; (right) Trench placed at 0.4 m from the building located in tensile zone.

The peripheral trench is composed of many blocks lining around the building model (Figure 7). The Figure 7 presents the material used the physical model and the material used to fill the trench. The building was positioned in maximum slope zone and in tensile zone (Figure 8).

Two distances of 1.4 m and 0.4 m between the trench and the building located in tensile zone were tested, whereas only a distance of 1.4 m was assigned for the building in maximum slope zone. The physical model allows estimating the efficiency of the peripheral trench by either comparing the horizontal strain in the building of the ground surrounding it under conditions with and without the presence of the trench. The trench was filled with very compressible material (foam).

The Table 2 presents the obtained results for two positions two in tensile zones and one in the maximum slope zone, with and without trench. For structure located in maximum slope zone, the average compressive strains in Table 2 shows a reduction of almost 70% of the horizontal strain of the ground surrounding the building in the case with trench compared to the case without trench.

Table 2. Average horizontal strains of building and its surrounding ground.

DTB: Distance between Trench and Building

ϵ_{hg} : ground horizontal strain, ϵ_{hb} : building horizontal strain,

Gr: ground, B: Building

WOT: Without Trench, WT: With Trench,

Building's position	DTB (m)	ϵ_{hg} (mm/m)		ϵ_{hb} (mm/m)		Strain reduction (%)	
		WOT	WT	WOT	WT	Gr	B
Max. slope zone	1.4	-2.88	-0.93	-0.20	-0.13	67.7	35.0
Tensile zone	1.4	-2.26	-1.79	-0.16	-0.07	20.8	56.3
	0.4	-	-	-0.16	-0.10	-	37.5

On the other hand, the reduction is equal to 35% if building strains are considered. For the structure located in tensile zone, the trench reduces about 21 % of the surrounding ground strain. Around 56% and 38% of strain reduction are found for buildings with trenches respectively at 1.4 m and 0.4 m distance.

From the obtained results, we can provide the following judgments:

- The efficiency of the trench depends on the position of the building. In terms of ground strain, the trench is much more effective for the maximum slope position; while it is less effective, regarding to the building strain.

- The closer the distance between the building and the trench, the less effective is the peripheral trench.

The physical model makes it possible to estimate the effectiveness of the peripheral trench by either comparing the horizontal strain in the building or the strain of the ground surrounding it under conditions with and without the presence of the trench.

The efficiency of the trench analysed by physical modelling is very similar to the results from observations in real cases (Peng et al. 1996) and those from numerical modellings. This clearly shows the effectiveness of the trench.

2.4 Trench filling materials

The success of the periphery trench to protect building depends on the filling material. The filling material must have the properties to reduce the initial volume (Figure 9). Several requirements must be met: compressibility or compactness, cost embodiment, sustainability, pollution, flammability, etc. The foam cannot be used due to the long term behavior.



Figure 9. Example de peat, limestone and coke material for filling the trench.

We selected several potential materials: coke, gravel, peat/straw, Honeycomb, insulating, used tires. We analyzed their physical and mechanical characteristics. Table 3 presents the advantage and disadvantages of each potential filling material according different technical and cost-effective criteria. Peat, straw and gravel may be considered as very useful material to fill the trench.

Table 3. Different indicators for the selecting the filling material (+ positive, - negative, = indifferent)

E: Efficiency, Ec: Ecologic, D: Durability, R: Realization, P: Price

Material	E	Ec	D	R	P
Coke	-	=	++	+	-
Gravels	+	=	++	-	++
Peat/Straw	++	=	=	+	+
Honeycomb structures	++	=	+	=	-
Used tires	++	+	+	+	++
Insulating	+	-	≈	-	-

3 CONCLUSION

The small-scale physical modelling (1g) tests were carried out to study the behavior of a mitigation technique – i.e. periphery trench - which may be used to reduce the damage to buildings due to ground movements. The periphery trench described in this paper has proved very effective in reducing the compressive strain in the ground and also in the building. The physical modelling results confirmed the numerical and in-situ experiences.

Its efficiency varies depending on the building location relatively to the subsidence trough, and on the distance from the building. The trench may reduce the horizontal strain by more than 50%. This result confirmed the main interest of periphery trench as mitigation solution.

Different materials were analyzed to fill the trench. Those materials must be enough compressible for short and long term protection. The trench is efficient when the filling material is very compressible, its Young modulus must be about 10% of that of the soil. The using of very deformable material like peat and straw gives acceptable results regarding technical and economic criteria.

4 REFERENCES

Al Heib, M. Emeriault, F. Caudron, M. Nghiem and L, Hor B. 2013. Large-scale soil-structure physical model (1g) assessment of structure

damages. *International Journal of Physical Modeling in Geotechnics*: 138-52.

Al Heib, M. 2008. Influence de la déformation horizontale sur le bâti. Rôle d'une tranchée périphérique", *Journées Nationales de Géotechnique et de géologie de l'ingénieur, LCPC-Nantes*. 159-166.

Bazanzurita, E. Gutierrez, J.J. Rizzo, P. 2012. Mitigation and Monitoring of Structural Distress due to Mine Subsidence, 5th European Conference on Structural Control Genoa, Italy. 18-20.

Deck, O. Al Heib, M. and Homand, F. 2003. Taking the soil-structure interaction into account in assessing the loading of a structure in a mining area. *Engineering Structure* 25: 435-448.

Garcia, D. 2001. Mesure de formes et de champs de déplacements tridimensionnels par stéréocorrélation d'images. PhD thesis, Institut National Polytechnique de Toulouse, France.

Hor, B., Emeriault, F., Caudron, M. and Al Heib, M. 2012. Analyse expérimentale de l'impact de mouvements de terrain sur le bâti de surface, *Journées Nationales de Géotechnique et de Géologie de l'Ingénieur, France*.

Lake, LM. Rankin W.J and Hawley J 1992. Prediction and effects of ground movements caused by tunnelling in soft ground beneath urban areas. CP/5, CIRIA Funders Report.

Peck, R.B. 1969. State of art: Deep excavation and tunneling in soft ground. *Proceeding of the 7th International Conference of Soil Mechanics, Mexico*.

Peng, S.S., Luo, Y. and Dutta, D. An Engineering Approach to Ground Surface Subsidence Damage Due to Long-wall Mining, *Mining Technology*, 78(900). 227-231.